

Contents 目录

2. Scope of validity 有效范围.....	2
2.1 Purpose 目的	2
2.2 Area of application 应用领域.....	2
2.3 Packaging recommendation for initial sampling 初次取样包装建议	2
3. Packaging and freight costs 包装与运输成本	3
3.1 Allocation of packaging and freight costs 包装与运输成本分摊.....	3
3.2 Incoterms®	3
4. Deliveries to foreign subsidiaries (and intercompany deliveries)	5
向海外子公司发货（公司间交货）	5
5. Selecting the packaging 选择包装.....	6
5.1 Packaging quality requirements 包装质量要求.....	6
5.1.1 Importance of the shipping method 运输方式的重要性	6
5.1.2 Materials / Reusability 材料/重复使用	7
5.1.3 Hygiene requirement 卫生要求	9
5.2 Fastening and load securing-homogeneous packaging 锁扣固定与装载安全-同质包装.....	9
5.3 Definition of packaging types / transportation aids 包装类型定义/运输辅助.....	10
6. Component-specific packaging provision 货物专用包装规定.....	15
7. Labelling, marking, sorting 标签、标记、分类	18
7.1 Delivery note 送货单	18
7.2 Sorting by load carrier 按载运工具分类.....	18
7.3 Labelling 标签	18
7.3.1 Labels/goods tags 标签/货签	18
7.3.2 IPPC Standard IPPC 标准	19
7.3.3 Sensitivity labeling (HPE Standard) 敏感性标签（HPE 标准）	19
8. Consequences of non-observance 违规后果.....	22
9. General 常规信息	23
9.1 Goods delivery and dispatch times 货物交付与发货时间	23
9.2 Address list of IKA sites: IKA 工厂通讯录:	23

1. Amendment history 修订记录

Index 序号	Brief description 概述	Date 日期	Name/Dept. 姓名/部门
	New version 新版发布	10.10.2011	AVE/ IE , MRO/ QS

2. Scope of validity 有效范围

2.1 Purpose **目的**

The "Packaging Policy for Suppliers" is intended to provide suppliers and IKA® internal personnel with information as an aid for the use of packaging and managing shipments. It is intended to indicate to individuals/offices how goods should be packaged securely and properly.

“供应商包装政策”旨在为供应商以及 IKA®内部员工提供有关于包装使用和装运管理的辅助信息。本政策旨在指导个人/办事处如何安全稳妥地对货物进行包装。

It is simultaneously:

同时还可以:

a support tool for purchasers to indicate to suppliers the proper packaging to be used for deliveries to IKA® worldwide an aid to IKA® shipping offices worldwide for training staff.

作为采购员支持帮助工具，告知供应商在向全球 IKA®交付货物时应当采用何种妥善包装，并能帮助 IKA®全球装运出货办事处进行员工培训。

2.2 Area of application **应用领域**

This packaging policy is a recommendation for suppliers to IKA® sites and their subsidiary companies. If country-specific legislation conflicts with recommendations, this packaging policy should be applied correspondingly.

本包装政策是针对 IKA®供应商及其分支子公司而提出的建议意见。如果特定国家的相关法规要求与本建议冲突，则本包装政策应予实施。

This packaging policy is a recommendation only. Wherever possible, the following remarks include information on additional help/addresses. IKA® specifically points out that the contents of this policy do not exonerate the individuals/offices concerned from liability for damages, especially damages caused by faulty packaging or inadequate corrosion protection.

本包装政策仅作为参考建议。如可行，下列备注讲解还可提供额外的帮助/地址信息。IKA® 特别指出：本管理规定不豁免任何个人/办事处的损坏赔偿责任，尤其是包装或防腐问题导致的损坏。

Furthermore, the individual/office concerned is not released from the duty to provide information on any regulations applicable to packaging and packaging materials.

此外，相关个人/办事处同样有责任提供适用于包装和包装材料相关规定和信息。

2.3 Packaging recommendation for initial sampling **初次取样包装建议**

At the time of initial sampling, a recommendation for production packaging (in accordance with the categories set out in section 6) should be provided by the supplier.

在初次取样之时，供应商应提供生产包装相关的建议（按照第 6 节中规定的分类目录）。

If no adequate packaging has been defined by the supplier/IKA® at the time of the initial sampling, the supplier is to ensure that suitable packaging has been selected. Packaging should protect the initial sample appropriately against transportation damage and external influences (e.g. corrosion).

IKA® Arbeitsanweisung / work instructions 作业指导	IKA® Packaging policy for supplier / intercompany shipments IKA® 供应商/公司间出货装运包装政策	Seite / page 页码 3 / 24
---	---	---

如果初次取样时供应商/IKA® 并未对适量包装做出规定，则供应商需确保选用适当的包装。初始取样的包装应可提供妥善保护以避免样本遭受运输损坏或外部影响（例如，腐蚀）。

3. Packaging and freight costs 包装与运输成本

3.1 Allocation of packaging and freight costs 包装与运输成本分摊

Any packaging and freight costs shall be accounted for separately as a matter of principle.

原则上任何包装与运输成本均应独立记账。

3.2 Incoterms®

What are Incoterms®? Incoterms®是什么？

Incoterms® (International Commercial Terms) are standardized clauses for rights and obligations during transportation associated with international agreements for the purchase of goods.

Incoterms® (国际贸易术语)是针对国际货物采购协议中运输安排相关权利义务的标准条款解释。

They were first published by the International Chamber of Commerce (ICC) in Paris in 1936.

通则最早于 1936 年由巴黎国际商会（ICC）出版发行。

INCOTERMS® are not international law that must be applied automatically. Rather, they are a proposal from the ICC that can - but not must - be applied. Therefore they must be expressly agreed upon by the contracted parties.

INCOTERMS®并不属于必须自觉遵守的国际法。相反，这些条款解释仅为 ICC 的惯例解释 – 不一定要加以引用。因此，国际贸易术语必须经由合同双方在合同中明确同意使用才具备约束力。

The ICC Incoterms® are generally recognized today at the international level and are supported by the United Nations Commission on International Trade Law (UNCITRAL).

ICC Incoterms® 在国际范围内已经获得广泛的认可，而且还取得联合国国际贸易法律委员会(UNCITRAL)的大力支持。

What do Incoterms® govern?

Incoterms® 管理范围

Incoterms® govern the following areas:

Incoterms® 主要用于下列领域的管理：

- **Transportation costs 运输成本**
- (Who bears the costs to which location?)
- (由谁来承担运输成本，承担多少？)
- **Transfer of risk 风险的转移**
- (Who bears the risk of transportation, e.g. damage to or loss of goods, to which location?)
- (由谁来承担运输风险，如货物的损失或丢失，承担多大运输风险？)
- **Delivery and acceptance of goods 交货与收货**
- **Required documentation for delivery 交货证明所需的文件资料？**
- (Who provides the required documentation or stamps?)
- (由谁提供所需的文件资料或公章证明？)

The following areas are not governed by Incoterms®:

以下领域不受 Incoterms®所约束：

IKA® Arbeitsanweisung / work instructions 作业指导	IKA® Packaging policy for supplier / intercompany shipments IKA® 供应商/公司间出货装运包装政策	Seite / page 页码 4 / 24
--	---	------------------------------

- **Transfer of ownership** 所有权的转移
- **Payment processing** 付款处理
- **Legal domicile and applicable law** 法定地址与适用法律
- **Liability disclaimers** 免责
- **Shortages and impairment of performance** 短装及货损

The relevant Incoterms® shall be observed.

相关 Incoterms®规定应遵守。

7 Incoterms clauses for any type or combination of transportation (multimodally applicable):

针对所有运输方式或运输方式组合（多式联运）的 7 种 Incoterms 术语：

EXW (ex works) （工厂交货）

FCA (free carrier) （货交承运人）

CPT (carriage paid to) （运费付至）

CIP (carriage and insurance paid to) （运费与保险费付至）

DAP (delivered at place) （目的地交货）

DAT (delivered at terminal) （目的港交货）

DDP (delivered duty paid) （完税交货）

4 Incoterms clauses for transportation by seagoing and inland vessels:

针对海运和内河运输的 4 种 Incoterms 术语：

FAS (free alongside ship) （船边交货）

FOB (free on board) （船上交货）

CFR (cost and freight) （成本与运费）

CIF (cost, insurance and freight) （成本、保险与运费）

NOTE: All information is provided for a rough and general overview. In practice, reference should be made to the official guidelines of the International Chamber of Commerce (ICC) on interpreting Incoterms® trading clauses, and all information in the official wording should be observed completely. An expert lawyer should be consulted for legal advice.

注：上述信息均为概述。在实务操作中，请参考国际商会（ICC）针对于 Incoterms® 贸易术语的官方解释，官方表述中的所有信息均应予以全面遵守。请咨询专业律师，以获取相关法律建议。

Incoterms® are issued by the International Chamber of Commerce (ICC). Only the text version issued by the ICC is binding.

Incoterms®由国际商会（ICC）制定出版。仅 ICC 版本中的文字表述具备约束力。

All trade names, brand names and styles used are the property of the relevant owner and are only used here for the purposes of description. Incoterms® is a brand of the International Chamber of Commerce.

此处所用到的一切商标名、品牌名以及样式均为其相应所有人之专有财产，在本规定内仅出于讲解说明之目的而加以使用。Incoterms® 为国际商会注册商标。

All contributions and content are journalistically researched. Nevertheless, no liability is accepted.

所有稿件及内容均可搜索，公司对此概不负责。

IKA® Arbeitsanweisung / work instructions 作业指导	IKA® Packaging policy for supplier / intercompany shipments IKA® 供应商/公司间出货装运包装政策	Seite / page 页码 5 / 24
--	---	------------------------------

All rights reserved. © 2009 - 2011 **Logistics law information**. No responsibility is taken for the correctness of this information.

保留所有权。© 2009 - 2011 **物流法律信息**。对于本信息之正确性我方概不负责。

Source: <http://www.incoterms2010-aktuell.de>

资料来源: <http://www.incoterms2010-aktuell.de>

4. Deliveries to foreign subsidiaries (and intercompany deliveries)

向海外子公司发货（公司间交货）

The packaging must be selected in such a way that transportation damage is prevented when shipping by air or sea freight.

选择包装时，应保证货物在空运或海运的运输过程中避免受到损坏。

- **Wooden packaging 木质包装**

Wooden packaging must be handled in accordance with ISPM Standard no. 15.

木质包装必须按照 ISPM 第 15 号标准加以处理。

For detailed information, please see: www.suedlicher-oberrhein.ihk.de,

欲知更多详情，请参见: www.suedlicher-oberrhein.ihk.de,

Alternatively: plastic or INKA pallets

另有: 塑料栈板或 INKA 栈板

- **Electronic export declaration (ATLAS export) 出口电子申报（ATLAS 出口）**

With goods valued in excess of €1,000.00 or with a freight weight in excess of 1,000kg an electronic export declaration must be generated.

当货物价值超过€1,000.00 或运输重量超过 1,000kg 时，必须进行出口电子申报。

For detailed information, please see www.zoll.de, here: EN home page > Entry and exit summary declaration (ICS)

欲知更多详情，请访问 www.zoll.de，进入 EN home page > Entry and exit summary declaration (ICS)

- **Customs/EORI number 海关/EORI 编码**

In order to be able to export goods, a customs or EORI number is required.

为利于货物出口，应提供海关编码或 EORI 编码。

This can be requested for free from the Customs' Information and Knowledge Management (Customs' IKM) in Dresden.

可从德累斯顿的海关信息与知识管理局（海关 IKM）处免费索取。

For detailed information, please see www.zoll.de, here: EN home page > Entry and exit summary declaration (ICS)

欲知更多详情，请访问 www.zoll.de，进入 EN home page > Entry and exit summary declaration (ICS)

- **Customs tariff number 海关税则号**

IKA® Arbeitsanweisung / work instructions 作业指导	IKA® Packaging policy for supplier / intercompany shipments IKA® 供应商/公司间出货装运包装政策	Seite / page 页码 6 / 24
--	---	------------------------------

In order to generate an export declaration, a customs tariff number is required for every item (possible alternative designations include statistical article number, customs code, HS code, CN code, article number). If the customs tariff number is not known, it must be identified in advance. This is done by consulting the book entitled "Warenverzeichnis für die Außenhandelsstatistik" ("Commodities Index for Foreign Trade Statistics"), also available free on the internet at www.zoll.de, here: EN home page > Entry and exit summary declaration (ICS) or www.destatis.de > Außenhandel>Klassifikationen>Warenverzeichnis für die Außenhandelsstatistik

要进行出口申报，所出口的每一件商品均需提供海关税则号（其他常见表述包括商品统计号、海关编码、HS 编码、CN 编码、商品编码等等）。如果海关税则号不明确，请务必提前予以确定。可以查阅名为"Warenverzeichnis für die Außenhandelsstatistik"（“对外贸易统计商品索引”）的数据，也可以从网上免费浏览：www.zoll.de，进入 EN home page > Entry and exit summary declaration (ICS) 或者 www.destatis.de > Außenhandel>Klassifikationen>Warenverzeichnis für die Außenhandelsstatistik

- Transportation and packaging costs are assumed by the IKA® subsidiary based abroad, by agreement.
- 根据协议规定，运输与包装成本均由 IKA®的海外子公司承担。
- The IKA® subsidiary assumes the bank fees for its own domestic branch.
- IKA®子公司要负责承担国内分支机构的银行费用。
- The correct article values must always be stated identically on all documents.
- 所有单据上的商品价值必须始终保持一致。
- Export is generally carried out via Spedition Schenker, unless there is another instruction on the order from the relevant IKA® subsidiary.
- 出口操作通常由 Spedition Schenker 负责完成，但相关 IKA®子公司的订单中另有指示的情况除外。
- Your contacts are the individuals named in the enquiry/order.
- 您的联系人信息可查阅询价单/订单上列出的姓名资料。

5. Selecting the packaging 选择包装

5.1 Packaging quality requirements 包装质量要求

5.1.1 Importance of the shipping method 运输方式的重要性

The shipping packaging shall be suitable for the intended standard means of transportation and must be adapted as appropriate to any change of shipping method.

运输包装应当与适合标准的运输方式相匹配，而运输方式一旦发生任何改变则运输包装必须进行对应的调整。

For example, if sea freight applies as the standard shipping method for a component, but for delivery date reasons relating to the order the item is being shipped by air freight, the shipping packaging must be adapted to the change in requirements.

例如，如果海运作为部件商品的标准运输方式，但由于订单规定的交货日期等原因，商品需要改为空运发货，则运输包装必须相应调整，以满足变化后的要求。

The various infrastructures in the countries of dispatch and delivery must be taken into consideration, for example: manual handling of goods, poor roads, high levels of traffic (stop and go) etc. Furthermore, all current customs and safety conditions in the country of delivery must be adhered to.

IKA® Arbeitsanweisung / work instructions 作业指导	IKA® Packaging policy for supplier / intercompany shipments IKA® 供应商/公司间出货装运包装政策	Seite / page 页码 7 / 24
---	---	---

发货国和交货国的各类基础设施情况也必须考虑在内，例如：货物需要人工装卸搬运、路况不良、交通不畅（停停走走）等等。此外，还必须遵守交货国中所有现行海关规定和安全规定。

The following shipping methods are available for selection. Combinations are possible:

有如下运输方式可供选择。多式联运也存在可行性：

Sea freight 海运

- Long transportation times 运输时间长
- Increased risk of corrosion 腐蚀风险增加
- Frequent freight turnover 货物周转频繁

Air freight 空运

- Extreme temperature variations 极端温度变化
- Light, space-saving packaging for optimum protection 轻质小巧的包装，提供最佳保护
- Strong acceleration and deceleration forces 加速和减速时受力强劲

Commercial road vehicle / rail transportation 公路商业运输/铁路运输

- Frequent freight turnover 货物周转频繁
- Impact loads 装载影响
- Greater environmental influences (dust, soot particles, rain) 环境影响更大（尘土、煤灰颗粒、雨水）

5.1.2 Materials / Reusability 材料/重复使用

Renewable and non-renewable raw materials 可再生和不可再生原料

With IKA® packaging and packaging systems, materials made of renewable raw materials (e.g. cardboard) should be used, ideally. Materials made of non-renewable raw materials (e.g. plastics) should only be used when more advantageous for commercial or quality reasons.

在 IKA® 包装与包装系统中应尽量使用可再生原料制成的材料（如纸板）。不可再生原料（如塑料）制成的材料仅应在有利于商业利益或质量的前提下使用。

Use of reusable packaging 重复使用的包装

With sophisticated packaging systems, there is the option of declaring these as circulating or multi-use packaging where it makes sense for commercial reasons (e.g. lower transportation/storage costs).

在成熟的包装体系下，出于商业需要，可以选择使用可循环使用或多次复用的包装（如降低运输/仓储成本）。

If reusable packaging is used, the following must be observed:

如果启用可重复使用的包装，请务必遵守以下要求：

- Only use reusable packaging that is in good working order.
- 仅使用性能状态良好的再生复用包装。
- Packaging must be clean and correspond to the IKA® hygiene requirements.
- 必须保证包装的干净整洁并符合 IKA® 的卫生要求。
- Empty goods are handled by IKA®.
- 由 IKA® 负责将包装内的物资清空。

Recycling 循环使用

All delivered disposable and multi-use packaging must be entirely recyclable. Labeling on disposable packaging must be clearly visible (e.g. RESY symbols, labeling of plastics etc).

所有交货时使用的一次性包装和多次复用包装必须保证完全回收。一次性包装上的包装必须清楚明显（如 RESY 符号、塑料标签等）。

Legal requirements/guidelines 法律要求/指导

****Semi-part**** packaging must comply with the Duales System Deutschland GmbH criteria, the EU Directive on Packaging and Packaging Waste and the assessment system in use in the preferred country of application (e.g. IKA® foreign subsidiaries).

****半成品****包装必须符合 Duales System Deutschland GmbH 公司的标准，符合包装与包装废料欧洲指令以及首选使用国家的使用评估体系（如 IKA®海外子公司）。

The packaging must adhere to the legally defined cumulative threshold value of 100 ppm for lead, cadmium, mercury and chromium VI.

包装必须符合法律定义的100ppm铅、镉、汞和铬VI的累积临界值规定。

If serious reasons justify non-adherence to one of the guidelines from the perspective of the supplier, these reasons shall be presented plausibly and approved by IKA® on a case by case basis.

如有充分理由证明供应商违反上述指导要求，相关证明理由应予以论证，并由 IKA®视具体情况予以批准。

Materials 材料

Type 种类	Permitted materials 获准材料	Non-permitted materials 未获准材料
Cardboard paper 纸板/ 纸	Paper and board free of materials harmful to paper production 不带有害于造纸生产材料的纸与纸板	Paper and board with water-insoluble coatings, adhesives or incompatible admixtures 采用不溶水涂布、施胶处理或使用不相容混合料的纸和纸板
Corrosion-proof paper 防腐纸	VCI papers that can subsequently be materially reused in conjunction with paper/board. 最终可与纸/纸板一起重复使用的VCI纸。 VCI films that can subsequently be materially reused in conjunction with plastic films. 最终可与塑料薄膜一起重复使用的 VCI 薄膜。	Paper with incompatible admixtures, incompatibly impregnated or soaked paper (e.g. bitumen paper) 使用不相容混合料的纸，不相容树脂浸渍纸或浸泡纸（如腊青纸）
Plastics 塑料	Molded parts: PE, PP, PS 塑模件： PE, PP, PS Films/bubble wrap: PE with max. 5% printed surface area 薄膜/气泡包装：最大5%印花表面的PE Foam material: PE, PP, PS 泡沫材料： PE, PP, PS Strapping tapes: PE, PP, PS 捆扎带： PE, PP, PS Polystyrene molded parts 聚苯乙烯塑模件	Other plastic mixtures, rubber compounds, metal/plastic compound films, incompatibly impregnated and VCI plastic films, metal/plastic compounds, packaging materials containing PVC 其他塑料混合材、橡胶合成物、金属/塑料合成薄膜、不相容浸渍薄膜和VCI塑料薄膜、金属/塑料混合材、含PVC的包装材料

	Other plastic mixtures: PE, PP, PS 其他塑料混材: PE, PP, PS	
Metals 金属	Steel (including zinc-plated or painted), aluminum 钢铁 (包括镀锌或上漆的)、铝	tin-plated metals (tinplate), metals containing heavy metals 镀锡金属 (镀锡铁)、含重金属元素的金属
Wood 木质	Untreated solid wood and plywood, 未经处理的实木与胶合板	chipboards, coated or painted wood, wood shavings 胶合木板、涂层处理或上漆的木料、刨花
Padding materials 填密材料	Corrugated board, paper, bubble wrap 瓦楞纸板、纸、气泡包装	Chips made of vegetal products, polystyrene chips 植物碎片, 聚苯乙烯碎片
Glass 玻璃	Only when absolutely essential for reasons of chemical compatibility with the filling material 只有出于确保填充材料的化学相容性时方可使用	Fiber glass, mineral wool 纤维玻璃、矿物棉
Damp protection 防潮	Desiccant pouches, silicates, VCI films 干燥包、硅酸盐、VCI薄膜	Materials with contents harmful to health 所含成分对健康有害的材料

5.1.3 Hygiene requirement 卫生要求

The qualitative requirements for the component being delivered determine the level of cleanliness of the packaging. This is to be taken care of by the supplier. The method and cycle of cleaning shall correspond with IKA® requirements. Pallets, containers and packaging must be supplied in a clean condition.

交货部件产品的定性要求决定包装的清洁程度。这一点由供应商负责处理。清洁方式和周期应当符合 IKA® 的要求。栈板、集装箱以及包装必须保证清洁干净。

5.2 Fastening and load securing-homogeneous packaging 锁扣固定与装载安全-同质包装

The fastening material used shall be adapted according to the size and weight of the consignment. The fastening material should serve both to secure goods during transportation and prove originality of shipment.

所使用的固定材料应当按照装运货物的尺寸重量加以调整匹配。固定材料不但要在运输过程中固定保护货物, 而且还作为包装未被拆封的证据。

Suitable materials for this include:

对此所使用的适当材料包括:

- self-adhesive packing tapes 自粘式包装带
- wet adhesive tapes 湿胶带
- fabric adhesive tapes 胶布
- stretch film 缠绕膜
- metal and plastic tapes (for heavy consignments) 金属带与塑料带 (针对大件货物)



During selection, the weight, shape and material of the consignment should be considered. Metal/plastic tapes should be adequate for the task and not be stretched too tightly. Edge protection profiles and angle trims may be used if necessary.

在选择包装材料时，货物的重量、形状以及材质都要考虑在内。金属/塑料带应足可应付所有包装作业，但不应拉伸过紧。必要时请使用包边材料和边角平整材料。

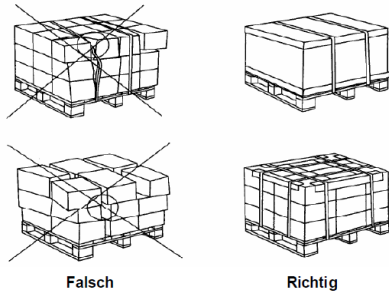

Falsch

Richtig

Homogeneous packaging 同质包装

Consignments shall ideally be packed with the articles consolidated. If such consolidated packing is not possible, the various consignments shall be clearly separated from one another and marked.

装运货物应当得到强化材料的包装保护。如果强化包装不可行，则不同的装运货物应当分开单独包装，并进行妥善标识。

Fillers 填充物

Empty spaces in boxes, euro containers, loading equipment and reusable packaging shall be filled with suitable fillers. This should then prevent individual components from colliding or shifting.

包装盒、欧标容器、装载机具以及重复使用包装内的空隙位置应当使用适当的填充物填充。使用填充物可避免货物之间相互碰撞或移位。

Important 重要提醒

Small parts should be packed with outer packaging either in bundles or in pallet boxes in such a way that they cannot become lost in the filler e.g. "5th batch of sealing rings d = 10".

小部件应当成捆包装或采用托盘包装在外包装上，以保证小部件不会隐秘在填料中，如“第 5 批密封圈 d=10”。

5.3 Definition of packaging types / transportation aids 包装类型定义/运输辅助

Pool pallet (euro standard) 平板托 (欧洲标准)

- External size 1200 x 800mm (Euro pallet as per DIN 15146 part 2)
- 外形尺寸1200 x 800mm (DIN 15146第2部分中规定的欧标托盘)
- No projection over the pallet surface area permitted.

- 托盘表面平坦无任何突起。
- Transportation height $\leq 2000\text{mm}$ (for air freight $\leq 1500\text{mm}$)
- 运输高度 $\leq 2000\text{mm}$ (空运时 $\leq 1500\text{mm}$)
- As per the quality requirements of the European Pallet Association (EPAL)
- 符合欧洲托盘协会 (EPAL) 的质量要求
- Maximum gross weight 1000kg
- 最大毛重1000kg

Disposable pallets 一次性托盘



- Length $\leq 1200\text{mm}$ 长度 $\leq 1200\text{mm}$
- Width $\leq 800\text{mm}$ 宽度 $\leq 800\text{mm}$
- No projection over the pallet surface area permitted.
- 托盘表面平坦无任何突起。
- Transportation height $\leq 2000\text{mm}$ (for air freight $\leq 1500\text{mm}$)
- 运输高度 $\leq 2000\text{mm}$ (空运时 $\leq 1500\text{mm}$)
- Maximum gross weight 1000kg
- 最大毛重1000kg
- Material quality determined from goods being conveyed
- 材料质量取决于运输货物的情况
- Transportable using standard forklift trucks
- 可使用标准叉车装卸转运

Wire mesh crate 铁丝框



Wire mesh crates should essentially be avoided and only used in exceptional cases.

尽量避免使用铁丝框，除非在极其特殊的情况下。

- External size 1200 x 800mm (Euro wire mesh crates as per DIN 15155)
- 外形尺寸1200 x 800mm (DIN 15155中规定的欧标铁丝框)
- Stackable 可堆叠
- As per the quality requirements of the European Pallet Association (EPAL)
- 符合欧洲托盘协会 (EPAL) 的质量要求
- Maximum gross weight 1000kg
- 最大毛重1000kg

Euro containers 欧标容器

These can be used for subcontracted work (extended work bench). Euro containers should not or should only in exceptional cases be used for purchased parts.

可针对用于分包作业（延展批量作业）。尽量避免使用欧标容器，除非针对极其特殊的外购部件。



- External size (length x width) 600 x 400mm and 400 x 300mm
- 外形尺寸（长 x 宽）600 x 400mm 及 400 x 300mm
- Permitted heights: 120mm, 220mm, 320mm
- 允许高度：120mm、220mm 和 320mm
- ESD implementation only required for electronic components (e.g. BLPs)
- ESD 的执行部署仅针对电子部件（如 BLP）
- Color: blue / ESD box black
- 颜色：蓝色/ESD 盒为黑色
- Maximum gross weight < 15kg
- 最大毛重 < 15kg

Recessed grips/handles must be provided

必须安装隐藏抓把/把手

Wooden crate 木箱



- The IPPC and HPE standards are obligatory 请务必遵守IPPC与HPE标准

The construction must be approved by IKA®. Furthermore the conditions of entry for the relevant IKA® foreign locations must be observed.

木箱结构必须获得IKA®的许可批准。另外还需要遵守相关IKA®海外机构的入境规定。

Disposable packaging 一次性包装

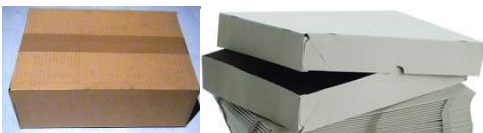

- Permitted exclusively for single use. 仅可使用一次。
- Length ≤ 600mm 长度≤ 600mm
- Width ≤ 400mm 宽度≤ 400mm
- Height ≤ 320mm 高度≤ 320mm
- Maximum gross weight < 15kg 最大毛重< 15kg

- Packaging quality determined from contents 包装质量取决于内装物
- Ideally with slip lids 最好使用滑启开盖

Postal or express parcels and separate consignments 邮政包裹或快递包裹与单独发货



Separate consignments and postal or express parcels should be adapted for the relevant shipping method.

单独发货与邮政包裹或快递包裹应与对应的运输方式相匹配。

- Length ≤ 600mm 长度≤ 600mm
- Width ≤ 400mm 宽度≤ 400mm
- Height ≤ 320mm 高度≤ 320mm
- Maximum gross weight < 15kg 最大毛重< 15kg
- Material quality determined from contents 材料质量取决于内装物

IKA® reusable packaging (UVP) IKA® 重复用包装



- Company-specific, standardized multi-use packaging 针对不同公司的标准化多次用包装
- External dimensions: 550 x 360mm 外形尺寸: 550 x 360mm
- Height: 160mm, 180mm, 250mm, 290mm 高度: 160mm、180mm、250mm 和 290mm
- Modular partition system for customized adjustment to goods being conveyed 模块分隔系统可根据所承运的货物进行适配调整
- Reusable packaging is provided by IKA 重复用包装由 IKA 提供
- The choice of reusable packaging is determined by IKA, taking commercial reasons into consideration
- 重复用包装的选用由 IKA 根据商业利益等方面的考量做出最终决定

IKA® has defined the following style for reusable packaging: 对于重复用包装, IKA® 的标识样式如下:

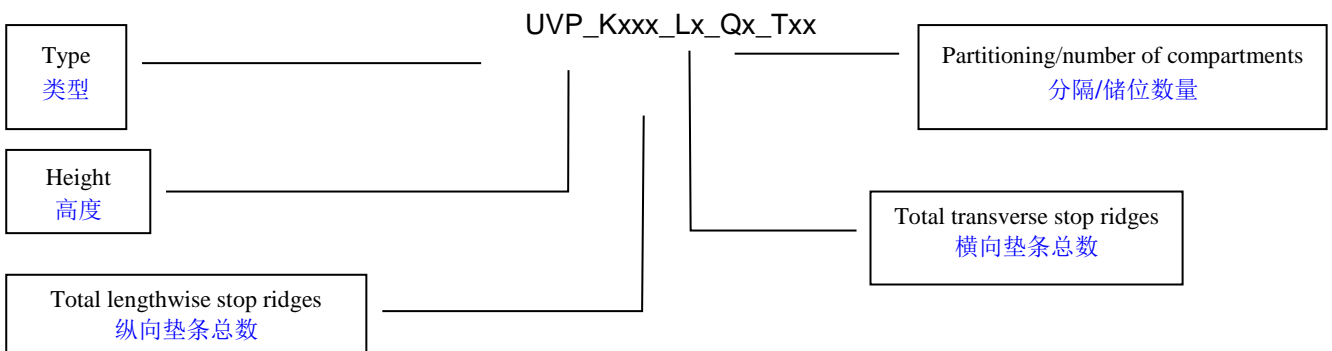

Example: 举例:

UVP_K250_L2_Q4_T09 => Reusable packaging - Height 250mm, 2 lengthwise stop ridges, 4 transverse stop ridges, 9 compartments

UVP_K250_L2_Q4_T09 => 重复用包装 – 高度 250mm, 2 根纵向垫条, 4 根横向垫条, 9 个储位



Blisters/Trays 泡沫垫/托盘



- Molded parts for appropriate components 针对特定部件的模块化组件
- Size depends on the outer packaging 尺寸取决于外包装情况
- Maximum gross weight < 15kg 最大毛重< 15kg
- Material quality determined from contents 材料质量取决于内装物

Special packaging 特殊包装

Special packaging should be avoided where possible and only used if no existing packaging system can be used. Standard dimensions for palletizing and logistics should be adhered to where possible. Special packaging shall only be used in consultation with IKA®.

应尽量避免使用特殊包装, 除非现有的包装体系无法起到任何作用。栈板包装与物流运输所使用的标准尺寸应尽量予以遵守。特殊包装只可在咨询 IKA®后加以使用。

Hazardous goods and best-before date 危险品与最佳使用日期



The current provisions for the transportation of hazardous goods must be observed. The supplier is liable for any damage arising from non-observance of the legal provisions.

必须遵守现行危险品运输规定。供应商必须对违反法律规定而造成的损失负责。

- Only packaging of a permitted design (e.g. cardboard packaging, canisters) that are constructed according to the regulation governing individual ADR classifications shall be used for transporting hazardous goods.
- 只有根据ADR分类相关规定制造并获得批准许可的包装设计（如纸板包装、圆罐）可用于危险品的运输。
- The consignment note or delivery note shall bear the relevant hazardous goods details (identification number, hazardous goods class, packaging group) as per the ADR.
- 托运通知或发货通知应附带ADR相关规定的危险品具体信息（识别编号、危险品分类、包装组别）。
- All shipped items with hazardous goods content shall be rendered clearly visible using the prescribed hazardous goods bill.

- 所有带危险品的运输物品应当在显眼位置张贴危险品标志。
- Details of any risk of water contamination are absolutely essential.
- 必须及时告知是否存在水污染危险的具体信息。
- With articles with a limited shelf life, the date of manufacture and expiration must be stated on the container (e.g. adhesives, paints, varnish).
- 如果货物的使用寿命有限制，则其生产日期和到期日必须在包装容器上明确标明（如贴标签、喷漆、抛光）

Corrosion prevention 防腐







Purchased parts that are inclined to corrode during transportation or storage shall be protected by the supplier, using suitable corrosion protection as agreed with IKA® (air-tight packaging, VCI corrosion prevention film/pouches, dry silicates, oil paper, grease/oil in exceptional cases).

供应商应使用经 IKA® 同意的适当的防腐保护措施，对在运输或存储过程中容易受到腐蚀的外购部件加以保护（气密包装、VCI 防腐薄膜/袋、干的硅酸盐、油纸、特殊情况下使用润滑油/油脂）。



6. Component-specific packaging provision 货物专用包装规定

Designation 指定编号	Parts category 部件分类	Explanation 解释	Sample photo 例图
A1	Dry bulk 干散货	<p>The separate parts should be protected against falling out and general dirt using a suitable box/film pouch.</p> <p>使用适当的盒子/薄膜袋将散装部件保护起来避免散落和污损。</p> <p>Maximum weight (15kg), stacking height and filling depth must be observed. Package batches shall be selected reasonably or shall be stipulated by IKA.</p> <p>最大重量（15kg），必须遵守堆垛高度和填充深度。应合理选取包装袋或按照 IKA 的规定选用。</p>	
A2	Dry bulk (ordered) 干散货（预订）	<p>Parts shall be packaged separately and orientated in a structured manner in batches of 50, 100, 500 and 1000. Maximum weight 15kg/box</p> <p>货物应当分开包装，有条理地将货物按批次分装，50、100、500 和 1000。最大重量 15kg/盒</p>	
B	Bundled parts 捆扎件	<p>Parts shall be bundled into appropriate batch sizes of e.g. 50, 100, 500 etc and should be protected against general damage. Maximum weight 10kg/bundle</p> <p>货物应当根据对应的批量规模来捆扎，如 50、100、500 等，必须能承受常规破坏。最大重量 10kg/捆。</p>	

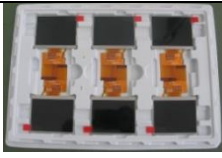
C1	Parts with low finish quality 抛光质量较低的货物	Basic protection of the parts should be guaranteed. Parts are allowed to be touching; gentle impacts are permitted. 应保证货物获得最基本的保护。允许接触到货物；允许轻微的碰撞。	
C2	Parts with high finish quality, design parts and sheet metal parts 抛光质量较高的部件和钢铁部件	Parts are not allowed to touch in the box; parts must be protected against impact. Empty spaces must be filled with a suitable filler; if possible use component-specific packaging. Use blisters or reusable packaging. Protective film may be required (see production drawing). 部件与包装盒之间禁止接触；部件之间不得发生碰撞。空隙部分必须使用适当的填料加以填充；如可行，请使用货物专用包装。使用泡沫垫或重复用包装。也可能要求用到保护膜（参见生产图纸）。	 
C3	Precision turned or milled parts 精致精加工或磨制的部件	Parts are not allowed to touch in the box. Parts must be protected against impact. Empty spaces must be filled with a suitable filler; if possible use component-specific packaging. Use a tubular net bandage, blister or reusable packaging. 部件与包装盒之间禁止接触。部件之间不得发生碰撞。空隙部分必须使用适当的填料加以填充；如可行，请使用货物专用包装。使用管状网带、泡沫垫或重复用包装。	 
D	Painted/coated body 喷漆/涂层主体	Specific parts packaging (ideally with partitions). Individual parts must be protected against impact. Empty spaces must be filled with a suitable filler. If necessary use reusable packaging or blisters. Individual parts should be packed in separate molded material (e.g bubble wrap). It must be possible to open without using tools. 专用部件包装（最好采用分隔存放）。各部件之间不得发生碰撞。空隙部分必须使用适当的填料加以填充。如可行，请使用重复用包装或泡沫垫。单体部件应当分开包装在塑模材料（如气泡包装）中。必须保证开启包装时无需使用工具。	 
E	Displays / front covers / membrane keyboards 显示器/封面/薄膜键盘	Front covers / membrane keyboards should be supplied with protective film on both sides and packed separately in batch sizes of 50, 100, 500 and 1000. 封面/薄膜键盘的两侧应当使用保护膜并按批量大小 50、100、500 和 1000 单独进行包装。 Displays must be supplied in appropriate molded	

		<p>packaging such as blister, punch and foam inlays.</p> <p>显示器必须使用合适对应的塑模包装如泡沫垫、袋子和薄膜内嵌等。</p>	
F	Assembled printed circuit boards 印刷电路板总成	<p>Each individual printed circuit board must be packed in an ESD film pouch if the circuit boards are not supplied in an ESD box. It must be possible to open the pouch without using tools. The circuit boards can be supplied in a box with partitions (ideally use slip lids).</p> <p>如果电路板没有使用 ESD 盒子包装，则单块印刷电路板必须包装在 ESD 薄膜袋内。必须做到无需工具即可开袋。电路板可以装入带有分隔储位的盒子内(最好使用)滑启开盖。</p> <p>Alternatively euro boxes with racks can also be used as reusable packaging.</p> <p>另外采用挂架的欧标盒也可用作重复用包装。</p>	
G	SMD components SMD 部件	<p>Standard feeder-suitable packaging should be selected (e.g. roll, magazines)</p> <p>应选择标准投放包装（如辊子、储料匣）</p>	
H	Special agreements / Exceptions (handling commodities) 特别约定/例外情况（搬运件）	<p>Special packaging/product-specific packaging should be avoided as far as possible. This must only be used in consultation with IKA®.</p> <p>应尽可能避免使用特殊包装/产品特殊包装。请务必仅根据 IKA®的咨询意见加以使用。</p>	
I	Equipment packaging, inlays, die cuts, collapsible boxes and other 设备包装、内衬、修边、折叠盒及其他	<p>Packaging should not be supplied folded. The load carrier should be protected against dirt; dampness and fading (e.g. stretch film, corrugated board).</p> <p>交货时包装不得出现任何折叠。载运工具应当保护货物免受尘土、潮湿以及褪色等影响（如缠绕膜、瓦楞纸板）</p>	

IKA® Arbeitsanweisung / work instructions 作业指导	IKA® Packaging policy for supplier / intercompany shipments IKA® 供应商/公司间出货装运包装政策	Seite / page 页码 18 / 24
--	---	-------------------------------

7. Labelling, marking, sorting **标签、标记、分类**

7.1 Delivery note **送货单**

Every shipping unit must have a delivery note attached. The delivery note must be easily visible, with a delivery note pocket attached to the consignment. In the event of multiple consignments or pallets, a packing list should also be generated and attached. Order details should be readable both as text and as a barcode (code 128).

每一个发货单元都必须随附送货单。送货单必须放在显眼的位置，货物上随附送货单外包袋。如有多项交货或多个栈板，则应当制作装箱清单并随货运输。订单信息应体现于文字上并写入条形码（代码 128）。

The following order details must be included on the delivery note:

发货单中必须列明如下具体信息：

- IKA® order number IKA® 订单编号
- IKA® article number with article designation IKA® 货号及货物名称
- Your IKA® supplier number IKA® 供应商编号
- Supplier article number 供应商货号
- Quantity 数量
- Customs tariff number and country of origin 海关税号和原产国
- Certificates (where necessary) 证书（如有必要提供）
- Batch number (where necessary) 批号（如有必要提供）
- Note partial deliveries; if possible state the delivery date of the balance
- 注明分批交货；如可行，请注明剩余部分的发货日期

Special agreements and concessions should be noted on the delivery note. Initial samples and test materials must be clearly marked or supplied separately.

特别约定以及让步决定应当在送货单中注明。初始取样与试验材料必须明确注明并单独发货。

7.2 Sorting by load carrier **按载运工具分类**

Where possible, effort should be made to put identical articles onto the same pallet. Avoid spreading identical articles across multiple pallets (homogeneous packing).

如可行，请尽量争取将完全相同的货物放到同一个栈板上进行包装运输。避免将相同货物放在不同栈板上包装运输（同质包装）。

If one delivery must consist of multiple articles, the components must be clearly marked (see section 3.1).

如单次货物交付中必须包含多种商品，各部件必须予以明确标识（参见 3.1 节）。

7.3 Labelling **标签**

7.3.1 Labels/goods tags **标签/货签**

Every shipment should be clearly marked. A label or tag with the shipping details (e.g. customer, delivery volume and order number) should be visible in both text form and in barcode form and attached to every shipment. The VDA 4902 goods tag can be considered as an IKA® standard. Information on this can be found in VDA Recommendation 4902 Version 4; this recommendation can be viewed on the VDA (German Association of the Automotive Industry) homepage:

每一批次装运都应明确标记。载有装货详细信息（如客户、交货数量以及订单号等）的标签或货签应当通过文字形式和条码形式表现出来并附在每一批次的装运货物上。VDA 4902 货签也可接受为 IKA® 标准。相关信息可通过 VDA 建议 4902 第 4 版中了解到；本建议可通过 VDA（德国汽车工业联合会）主页查询；

<http://www.vda.de/de/downloads/69>

(1) Warenempfänger BAYERISCHE MOTORENWERKE AG D-8000 MUENCHEN 40		(2) Abladestelle - Lagerort - Verwendungsschlüssel M PREYMESSER GMBH & CO KG SPEDITION ECHING B. MUENCHEN	
(3) Lieferschein-Nr. (P) 808916 		(4) Lieferantenanschrift (Kurzname, Werk, PLZ, Ort) HOESCH STAHL AG ZINCAL-WERK (5) Gewicht netto 10310	
(6) Sach-Nr. Kunde (P) 0 166 496 		(8) Gewicht brutto 10340	
(9) Füllmenge (Q) 10340 		(7) Anzahl Packstücke 2250 M (10) Bezeichnung Lieferung, Leistung RR ST 13 05 MONOZINC (11.1) Abmessung 0,80 X 0750,0 610	
(12) Lieferanten-Nr. (V) 57349611 		(11.2) Wkp 8813895302100 (13) Datum P 901016	
(15) Packstück-Nr. (S) 440010300010340		(14) Zink-Auflage 10,0/ 7,5 (16) Chargen-Nr. (P) 1481781001 	
(17) HOESCH STAHL AG ZINCAL WERK		Warenanhänger VDA 4902, Version 3 10:12 13.05.91	

7.3.2 IPPC Standard IPPC 标准

The IPPC Standard applies to the import and export of packaging material of a vegetal origin. Details on this can be found in the Regional Office for Plant Protection leaflet.

IPPC 标准适用于进出口货物包装材料的植物出产国。相关具体信息参见植物保护协会地方办事处分发的传单。

7.3.3 Sensitivity labeling (HPE Standard) 敏感性标签 (HPE 标准)

The HPE Standard is intended to act as an aid for the labeling of stress-resistant packaging for import / export. When selecting packaging the following points should be taken into consideration in order to guarantee the intact transportation of packaged goods:

HPE 标准旨在辅导进出口货物抗受力包装的标签制作。在选择包装时应当考虑到以下几点，以便保证被包装货物在运输过程中完好无损：

- Country / place of destination 国家/目的地
- Shipping route 运输路径
- Transportation method 运输方式
- Reloading 重复装载

- Storage 存储

However, the labeling does not exonerate the logistics chain from careful handling during transportation and storage.

贴标后，物流链的运输和存储过程中还需对产品小心处理。

No. 序号	Meaning of symbol 符号含义	Symbol 符号	Function 功能	Comments 说明
1	Breakable 易碎		The contents of this consignment are breakable and must therefore be handled with care. 本次装货内的货物极易破碎，必须小心轻放	ISO 7000, No. 0 621 Example of use: 使用举例:
2	do not use hooks 切勿使用吊钩		Use of hooks for handling the consignment is forbidden. 禁止搬运过程中对货物使用吊钩	ISO 7000 No. 0 622
3	Top 此端向上		Shows the correct upright position for the consignment. 指出货物正确的竖起位置	ISO 7000 No. 0 623 Example of use: 使用举例:
4	protect against heat 防高温		The consignment must be protected from heat. 必须保护货物免受高温影响。	ISO 7000, No. 0 624
5	protect against radioactive radiation 防辐射		The contents of the shipment can be impaired or rendered unusable by radioactive radiation. 此次承运的货物如被辐射则可能损坏或无法使用。	ISO 7000 No. 2 401

No. 序号	Meaning of symbol 符号含义	Symbol 符号	Function 功能	Comments 说明
6	protect from damp 防潮		The consignment must be stored in a dry environment. 货物必须存放于干燥环境内。	ISO 7000, No. 0 626
7	centre of gravity 重心		Indicates the centre of gravity of the consignment that is handled as a single unit. 指出单台机具搬运时货物的重心位置	see 2.4.1 and 2.4.3 ISO 7000 No. 0 627 参见 ISO 7000 No. 0 627 的 2.4.1 和 2.3.3 Example of use: 使用举例:
8	do not roll		The consignment must not	ISO 7000 No. 2 405

	切勿滚动		be rolled over. 货物一定不可以翻滚。	
9	do not use a sack truck 切勿使用手推车		Sack trucks should not be used on this side when handling the consignment. 搬运货物时,不得在这一端使用手推车	ISO 7000 No. 0 629
10	do not use a forklift 切勿使用叉车		The consignment should not be handled using a forklift. 货物不得使用叉车搬运。	ISO 7000 No. 2 406
11	clamp in the direction of the arrows 箭头所指位置使用夹具		Clamps must be applied on the sides indicated when handling the consignment. 搬运货物时必须指明的一侧使用夹具。	see 2.4.1 ISO 7000 No. 0 631 参见 ISO 7000 No. 0 631 的 2.4.1

No. 序号	Meaning of symbol 符号含义	Symbol 符号	Function 功能	Comments 说明
12	do not apply clamps in the direction of the arrows 箭头所指位置切勿使用夹具		The consignment should not be handled with clamps on the sides indicated. 搬运货物时不得在指明的一侧使用夹具	ISO 7000 No. 2 404
13	maximum stacking load weight 最大堆垛负重		Indicates the maximum weight of the consignment stacking load. 指出货物堆垛时的最大负重重量	ISO 7000, No. 0 630
14	stacking limit 堆垛限制		Maximum number of identical consignments that can be stacked, where <i>n</i> represents the permitted number of consignments. 同一货物可以堆垛的最大层数,其中 <i>n</i> 代表允许堆垛的数量	see 2.4.4 ISO 7000 No. 2 403 参见 7000 No. 2 403 的 2.4.4
15	do not stack 切勿堆垛		Stacking of consignments is not allowed and no load should be placed on top of the consignment. 不允许对货物进行堆垛,货物顶上禁止任何负重	ISO 7000 No. 2 402
16	fasten here 固定这里		Fasteners for lifting the consignment should be positioned as indicated.	see 2.4.1 and 2.4.3 ISO 7000 No. 0 625 参见 ISO 7000 No. 0 625 的

			起吊货物的紧固件按制定位置锁紧	2.4.1 和 2.3.3 Example of use 使用举例
17	permitted temperature range 允许的温度范围		Indicates the temperature range within which the consignment must be stored and handled. 指出货物在存储和搬运过程中的温度范围	ISO 7000 No. 0 632 Example of use: 使用范例:

8. Consequences of non-observance 违规后果

This packaging policy is a recommendation for the IKA® group, its subsidiaries and suppliers. This packaging manual should be applied correspondingly under obligatory observance of country-specific legislation.

本包装政策是针对 IKA®集团、其子公司及供应商的建议规定。本包装手册应当根据各国法规的具体内容进行遵守并调整使用。

We point out that the contents of this packaging policy document do not exonerate the company/individual involved from liability for any damage that might occur, such as faulty packaging or inadequate corrosion protection. Furthermore, the company/individual involved is not released from the duty to provide information on any regulations applicable to packaging and packaging materials.

特此指出，本包装政策之内容并不得免去公司/个人的损坏赔偿责任，尤其是包装不良或防腐保护不足导致的损坏。此外，相关公司/个人亦不得免于承担信息提供义务，即必须提供适用于包装与包装材料的相关地方规定的信息。

If the supplier does not observe this packaging policy and, for example, uses disallowed materials or exceeds the permitted consignment sizes or maximum weight, IKA® will take steps to protect the goods and minimize damage by unpacking, inspecting, repacking, relabeling and replacing the goods into storage and/or disposing of the inadequate packaging. The supplier will bear the costs of these measures. These will be calculated at an effective rate of €60.00 an hour, but will be €30.00 per delivery as a minimum.

如果供应商未能遵守本包装政策，如使用了未获准的材料或超出允许的货物大小或货物大小的，IKA®将采取措施对货物加以保护并通过升级包装、检验、二次包装、二次贴标以及替换货物储放和/或弃置不良包装等方式来最大程度减少损失。供应商将承担上述处理措施的相关成本。有效费率按€60.00/小时计算，但最低不得低于每次交货€30.00。

The supplier is liable as follows for damage that occurs through non-observance of this packaging policy:

由于违反本包装政策而造成的损失，供应商必须承担下列赔偿：

- The legal provisions governing materials defect liability shall apply to material damage to the goods.
- 材料缺陷赔偿责任的法律规定应同样适用于受到实质性损坏的货物。
- The supplier shall be liable for damage that has occurred to legally protected interests other than the goods themselves caused by inadequate packaging, including through ordinary negligence.
- 供应商不但要承担不良包装包括有意疏忽而导致的货物本身的损坏赔偿，还要承担受法律保护的权益的损坏赔偿责任。

The supplier is obliged to compensate IKA® for the damage that has occurred.

IKA® Arbeitsanweisung / work instructions 作业指导	IKA® Packaging policy for supplier / intercompany shipments IKA® 供应商/公司间出货装运包装政策	Seite / page 页码 23 / 24
---	---	--

供应商必须就出现的损失向 IKA® 予以赔偿。

9. General 常规信息

9.1 Goods delivery and dispatch times 货物交付与发货时间

Delivery and dispatch times can be found on our homepage www.ika.net.

交付与发货时间见公司首页：www.ika.net。

9.2 Address list of IKA sites: IKA 工厂通讯录:

IKA® Werke GmbH & Co. KG

Janke & Kunkel-Str. 10
79219 Staufen
Germany / Deutschland
Tel.: +49 7633 831-0
Fax.: +49 7633 831-98
Email: sales@ika.de

IKA® Werke GmbH & Co. KG

Janke & Kunkel-Str. 10
79219 Staufen
德国 / Deutschland
电话: +49 7633 831-0
传真: +49 7633 831-98
电邮: sales@ika.de

IKA® Works, Inc.

2635 North Chase Pkwy SE
Wilmington, NC 28405-7419
USA
Hotline: 800 733 3037
Tel.: +1 910 452 7059
Fax.: +1 910 452 7693
Email: usa@ika.net

IKA® Works, Inc.

2635 North Chase Pkwy SE
威灵顿, 北卡罗来纳 28405-7419
美国
热线: 800 733 3037
电话.: +1 910 452 7059
传真.: +1 910 452 7693
电邮: usa@ika.net

IKA® Works (Asia) Sdn Bhd

No. 17 & 19, Jalan PJU 3/50
Sunway Damansara Technology Park
47810 Petaling Jaya
Malaysia
Tel.: +60 3 7804 3322
Fax.: +60 3 7804 8940
Email: sales@ika.com.my

IKA® Works (Asia) Sdn Bhd

IKA® Arbeitsanweisung / work instructions 作业指导	IKA® Packaging policy for supplier / intercompany shipments IKA® 供应商/公司间出货装运包装政策	Seite / page 页码 24 / 24
---	---	--

No. 17 & 19, Jalan PJU 3/50
Sunway Damansara Technology Park
47810 Petaling Jaya
马来西亚
电话: +60 3 7804 3322
传真: +60 3 7804 8940
电邮: sales@ika.com.my

IKA® Works Guangzhou
Guangzhou Economic and Technological Development Zone
173 - 175 Friendship Road
510730 Guangzhou
China
Tel.: +86 20 8222 6771
Fax.: +86 20 8222 6776
Email: info@ika.cn
免费服务热线: 400-886-0358

IKA® Works Guangzhou
Guangzhou Economic and Technological Development Zone
173 - 175 Friendship Road
510730 Guangzhou
China
中国广州市经济技术开发区
友谊路 173 – 175 号
电话: +86 20 8222 6771
传真.: +86 20 8222 6776
电邮: info@ika.cn
免费服务热线: 400-886-0358

IKA® India Private Limited
814/475, Survey No.129/1 Mysore Road,
Kengeri,
560060 Bangalore, Karnataka
India
Tel.: +91 80 26253900 - 26253999
Fax.: +91 80 26253901
Email: info@ika.in

IKA® India Private Limited
814/475, Survey No.129/1 Mysore Road,
Kengeri,
560060 Bangalore 班加罗尔, Karnataka 卡纳塔克邦
India 印度
电话: +91 80 26253900 - 26253999
传真.: +91 80 26253901
电邮: info@ika.in