

ULTRA-TURRAX® Tube Drive System

Quicker and safer sample preparation

The disposable dispersing system ULTRA-TURRAX® Tube Drive control (UTTD control)

Before researchers and lab assistants are able to analyze samples, they usually have to prepare the material first. Mixing, crushing, dispersing or homogenizing processes tend to be quick. The cleaning of the machine, however, is time consuming and can be dangerous when working with toxic substances. But now, thanks to the new, hermetically sealed, disposable tube system, contact with the sample material is minimized and sample processing time is decreased.

So-called batch dispersing tools operate with reusable vessels. These vessels are filled with the sample material which is then homogenized and filled into other vessels. After the work is completed, the vessel and the tool, (the rotor-stator system or mill), must be cleaned and if necessary, sterilized. During handling there is always a danger of cross-contamination, e.g. an unwanted entry of particles from one sample into another. Users are at risk as well. In the event that infected cell materials or toxic substances are to be processed, any contact with the filled vessel or the used dispersing tool poses a risk of infection or poisoning. Cleaning and sterilization swallow up time. Therefore, in order

to prepare samples in a safer and quicker manner, a completely new system made up of a drive, dispersing tool and sample vessel was needed. The most important step was to integrate the dispersing tools into the sample vessel. The tool and the vessel create a unit and are designed to be a disposable product. After the sample preparation they can be discarded or stored.

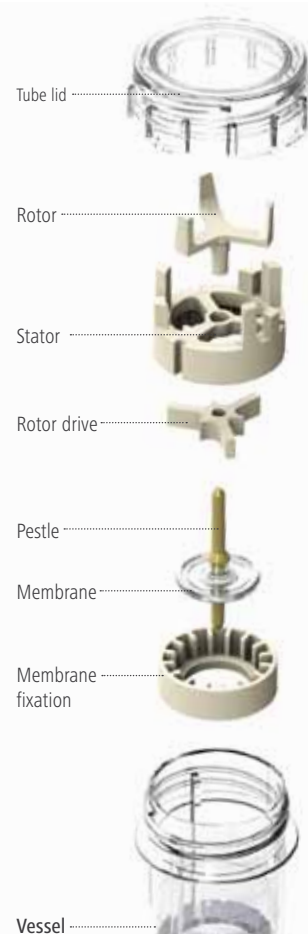



Closed tubes instead of open vessels

Disposable tubes represent the tool-vessel combination within the IKA® ULTRA-TURRAX® Tube Drive (UTTD). They are attached to the drive unit without the user coming into contact with the sample material. Upon test completion, a signal sounds. The sample can now be stored in the tube for further analysis with other devices.

The tubes can hold either 20 milliliters, (working volume of 2 to 15 ml) or 50 milliliters, (working volume of 15 to 50 ml). They come in three different models:

- > **ST-Tube:** Mixing vessel with an integrated stirring function. It is suitable for mixing, stirring, extracting, suspending and dissolving.
- > **DT-Tube:** Dispersing vessel with an integrated dispersing function. It is suitable for the dispersion, homogenization and suspension of e.g. medicinal samples.
- > **BMT-Tube:** Grinding vessel with integrated glass or stainless steel balls. It is suitable for dry crushing, cell maceration as well as the dissolution of tablets in liquids.

The UTTD and its unique tube system can process virtually all types of sample material, (see overview on page 4). Once the tubes are closed, they are hermetically sealed, even under speeds up to 8.000 revolutions per minute. Optional tubes with pierceable membranes allow for addition or removal of sample. Gamma sterilized tubes are also available for special test procedures.

Due to these characteristics, the UTTD is perfectly suitable for the following applications:

- > Dissolution of medications such as tablets or capsules prior to analysis
- > Dispersion of human or animal tissue
- > Dispersion of, or extraction from plants
- > Emulsification of cosmetic samples
- > Extraction of bacteria, (such as E. coli) with a ball mill tube, (glass balls)



Example: Homogenization of mint leaves with subsequent sampling



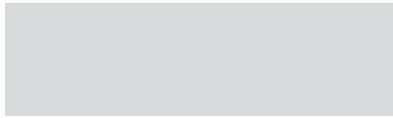

Application examples for the ST Tube

- > Dissolving properties of drugs
- > Incorporation of colored pigments into a solvent
- > Accelerated dissolution of sugar solutions
- > Extraction of plant substances
- > Accelerated dissolution of tablets, dragées, suppositories and capsules
- > Mixing of fluids with higher viscosities

liquid + powder



ST Tube:
Tube with stirring device
 Suitable for:

- > Mixing
- > Stirring
- > Extractions
- > Preparation of soil sample suspensions



Application examples for the DT Tube

- > Homogenization of tissue samples including: brain, liver, muscle tissue, kidney and lung
- > Milling of plant samples including: rosemary, rapeseed, tomato seeds, grapes, potatoes, cress, leaves and roots
- > Production of O/W and W/O emulsions
- > Homogenization of effluent samples

liquid + sample

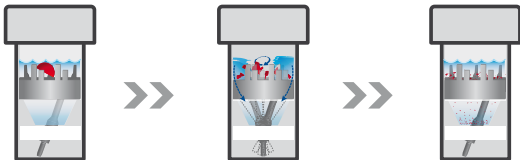

DT Tube: Tube with rotor-stator element
 Suitable for:

- > Dispersion
- > Homogenization
- > Suspensions
- > Pharmacokinetics
- > Metabolism studies
- > Diagnosis



Application examples for the BMT G/S Tube

- > Decomposition of animal, plant and human cells
- > Dry milling of pigments, building materials and coal samples
- > Dry milling of freeze-dried samples
- > Milling of samples to determine water content

balls + sample



BMT G / S Tube: Tube for grinding with glass balls (G) or stainless steel balls (S)
 Suitable for:

- > Dry milling of dry and brittle samples (e.g. kaolin, gypsum, colored pigments, tablets)
- > Cell maceration
- > Processing of materials mixed with fluids



4

The UTTD delivers its best reproducible results with the following materials:

Algae, amnion, apple leaves, brain of pigs, capsules, carrots, catalysts, cheese, cherry leaves, chicken meat lean, color pigments, compost, conductivity paste, cress seeds, crude oil, dry frozen leaves, fat cream, fibrin-cells, flavor capsules, food paste, fruit juice concentrates, fuel oil, giblets, grape leaves, grape pods, grass, heart, hop pellets, ivy, kidney, liver, lung, lymph nodes, malt pellets, medicine analeptic, muscle tissue, mushrooms dried, nematode, oil, ointments, oleander leaves, olives without stone, orange peel, pill, plant leaves, plant lice, plums leaves, pork meat, potato beetle, potatoes, potatoes shelled, raspberry leaves, rape, roots, rosemary, sage dried, salad oil, sediment, seeds, silicon carbide, sludge, soil samples, starch grains, sugar-coated tablet, sunflower kernels, textiles paints and pigments, thymus, tobacco leaves, tomatoes seeds, trachea, turkey liver, turkey meat, umbilical cord, vegetable, vegetable mixture, waste water, wood

Industries and areas of application:

- > Agriculture
- > Biology
- > Botany
- > Brewery
- > Building Materials Industry
- > Chemical Industry
- > Cosmetics
- > Ecology
- > Environmental Protection
- > Food Analysis
- > Genetic Research
- > Hematology
- > Human Medicine
- > Immunology
- > Medicine
- > Paint- and Varnish Industry
- > Pathology
- > Pharmacy
- > Petrochemistry
- > Tobacco Industry
- > Veterinary Industry





Controlling, programming, documenting with the ULTRA-TURRAX® Tube Drive control

The model ULTRA-TURRAX® Tube Drive control (UTTD control) offers users additional options.

A USB interface enables you to run the UTTD control and to document your test series on a PC utilizing IKA®'s software program: "labworldsoft®". A built-in program library allows for tests to be repeated under identical conditions.

In addition, the user can switch on functions manually in order to improve the mixing and crushing results. The turbo switch allows the user to increase the speed and the reverse switch lets him cyclically reverse the rotational direction. Both options help to optimize the mixing and crushing effect.

Test management and documentation of the UTTD control with the software program: "labworldsoft®"

Technical data

Motor rating input / output	20 / 17 W
Speed range / turbo speed	400 - 6.000 rpm / 8.000 rpm
Display	OLED
Speed display	digital
Timer	10 s - 30 min (infinitely adjustable)
Reversal of rotating direction interval	10 - 60 s

General data

Dimensions (W x D x H)	122 x 178 x 48 mm
Weight	1,0 kg
Protection class acc. to DIN EN 60529	IP 20



Advantages:

- > Disperse, stir, homogenize and grind using a single drive unit
- > No possibility of cross-contamination
- > Hermetically sealable disposable sample tubes
- > No cleaning required
- > High level of user safety
- > Suitable for individual use and use in series
- > Gamma-sterilized tubes
- > Tubes with pierceable membrane lids
- > Tubes with 2 - 15 ml and 15 - 50 ml
- > Anti-locking function
- > Increases safety due to low voltage (24 V)
- > Chemical-resistant plastic
- > Simple and safe disposal
- > Worldwide service guaranteed by IKA®
- > Reproducible tests
- > Patented



IKA® offers a free applications hotline:
00 8000 4522777 (00 8000 IKAPPS)*
E-Mail: applicationsupport@ika.de

* Monday - Thursday: 8.30 am - 4.30 pm
Friday: 8.30 am - 3.30 pm



Designed
to work perfectly

IKA®-Werke GmbH & Co. KG
Janke & Kunkel-Str. 10 · 79219 Staufen · Germany
Tel. +49 7633 831-0 · Fax +49 7633 831-98
sales@ika.de · www.ika.com

IKA®